

2L Technologies

Next Generation - Intelligent LON[®]
Fibre Optic Transceiver (SMX)



2L Technologies have developed the next generation of LON fibre transceivers (and routers), introducing a higher level of intelligent networking for LonWorks[®] applications. 2L Transceivers conform to the standard SMX format and provide a fibre optic network interface for any appropriately configured LonWorks[®] device or subnet. This allows the device to communicate with other LonWorks[®] nodes over a self healing fibre optic redundant ring network. 2L Transceivers are available as Multimode (up to 3Km between nodes) and as Singlemode (up to 80Km between nodes) The transceivers can be managed using LonBuilder[®], LonMaker[®] preferably - or with any appropriate third party LNS management software and SMX adapters using the same SMX format. 2L Fibre Optic Transceivers are a cost effective networking solution ideal for applications requiring high throughput, expandability, immunity to electromagnetic interference or communication over great distances (1metre to 80 Kilometers between nodes) - connecting point to point, or large multisite network backbones with hundreds of nodes, over a fully redundant, self healing, fibre ring.

- Connect Neuron devices using 'Next Generation' single-Fibre WDM Fibre optic SMX transceivers supporting 1.25Mbps or 2.50Mbps.
- Fibre LonTalk[®] Channel supporting current FO-20S, FO-20L and legacy FO-10.
- Real-time fault tolerant packet delivery technology, zero packet loss, zero collisions.
- Two full duplex Fibre ports with dual speed adaptable 1.25/2.50Mbps Neuron Port.
- Built-in automatic Fibre port self-testing provides real-time operational status, Fibre port LED indicates status, on-board neuron providing Fibre port status via network and mechanical relay activating on Fibre port link loss or Fibre port link failure. Relay can be user controlled via network.
- Supports 1.25Mbps or 2.50Mbps LonWorks[®] throughput, with large node count (100's)
- Uses WDM technology for Single-Fibre core communication - reduces installation cost by 50%
- Tailor to your application by mixing different fibre optic port types i.e. multimode/singlemode, 3km to 80km node hops, supporting special user requirements allowing for a more cost effective solution.
- Ring Redundancy / Self Healing, ensuring network integrity.
- LED Port link status for each Fibre port showing Fibre connectivity and health.
- Node status reporting via on-board Neuron chip to insure Fibre network reliability. Service request button for easy node installation, automatically updates node Neuron ID number to network when pressed. Neuron is user programmable via network.
- RoHS lead-free compliant.
- Operating temperature: 0C to +70C standard, extended temp -40C to +80C as an option.
- Humidity: 95% non-condensing
- Single +5 volt ± 0.25 VDC low power operation.
- Standard length SMX mechanical footprint.

Fault Tolerant Network using Ring Topology

All data is transmitted and received simultaneously using full duplex communication over a single Fibre cable. All data is transmitted in both directions always, with anti-packet-recirculation technology. If the Fibre ring is broken i.e. one Fibre port no longer is connected or node is powered off, all nodes remain connected in the presence of a single fault.

Node Status/Control Reporting via Network

On-Board Neuron is factory setup as “Configured Online”, user must press “service button” for network installation. {Neuron code can be created adapting to customer requirements.}

Node status reporting supported via the on-board Neuron Cypress CY7C53120E4-40SXI 32-pin SOIC as follows:

1. ‘Change’ in Fibre port i.e. *link loss, Link active or port failure* causes the node to send three current port status messages out to the network. On-board Neuron can be disabled via small slide switch on card.

Neuron ‘Network Variable’ Node Status provided as follows:

1. *NV Index-4 is “Relay Output”* Neuron pin-3 IO4:
{SMX connector pin-14 (3.3v ref.) drives base of user NPN transistor to activate user relay.}
 - a. Logic-0 causes relay common & relay normally-closed to be shorted, relay de-activated.
 - b. Logic-1 causes relay common & relay normally-open to be shorted, relay activated.
2. *NV Index-5 is “Relay Enable”* Neuron pin-30 IO5:
 - a. Logic-0 relay indicates combined fibre ports health status, Relay activates on fibre port *link loss or fibre port failure*.
 - b. Logic-1 enables user to control relay.
3. *NV index-6 is “Right Fibre Port Status”* Neuron pin-7 IO0:
 - a. If “Port Failure”= Logic-0 then
 - i. If “Right Fibre Port Status” = Logic-0 then no fibre port link.
 - ii. If “Right Fibre Port Status” = Logic-1 then fibre port link ok.
 - b. If “Port Failure”= Logic-1 then
 - i. If “Right Fibre Port Status” = Logic-0 then fibre port operating ok.
 - ii. If “Right Fibre Port Status” = Logic-1 then fibre port failure.
4. *NV Index-7 is “Left Fibre Port Status”* Neuron pin-6 IO1:
 - a. If “Port Failure”= Logic-0 then
 - i. If “Left Fibre Port Status” = Logic-0 then no fibre port link.
 - ii. If “Left Fibre Port Status” = Logic-1 then fibre port link ok.
 - b. If “Port Failure”= Logic-1 then
 - i. If “Left Fibre Port Status” = Logic-0 then fibre port operating ok.
 - ii. If “Left Fibre Port Status” = Logic-1 then fibre port failure.
5. *NV Index-8 is “Network Status”* Neuron pin-5 IO2:
 - a. Logic-0 means fibre network is linear bus not operating redundantly.
 - b. Logic-1 means fibre network is operating redundantly.
6. *NV Index-9 is “Port Failure”* Neuron pin-4 IO3:
 - a. Logic-0 means both fibre ports are operating correctly.
 - b. Logic-1 means one or both fibre ports have failed, i.e. packets received on the fibre port are corrupted, CRC packet errors or no packets received while port is linked.

Node Status Reporting via LED indicators

Fibre port LED Left/Right Status:

1. 'Solid green' LED means *link ok*, the fibre port is receiving link signals from far node and the fibre network is operating redundantly.
2. 'Solid yellow' LED means *link ok*, the fibre port is receiving link signals from far node and the fibre network is operating as linear bus.
3. 'Fast blinking yellow' LED {200ms on/off} means *link loss* i.e. no link pulses received from far end node.
4. 'Slow Blinking yellow' LED {800ms on/off} means *port failure* i.e. packets received on this fibre port are corrupted, CRC packet errors or no packets received while port is linked.

On-Board Neuron Service LED Status:

1. 'Blinking blue' LED means on-board Neuron is not 'configured'.
2. 'Solid blue' LED means on-board Neuron service request.

Node Status & Control Relay via Network

The on-board mechanical relay provides node status of fibre ports by activating when the fibre port link is lost or fibre port failure. The relay can be remotely controlled via network management, supporting equipment remote control i.e. lighting, pumps, motors etc. The on-board mechanical relay provides SPDT operation supporting the following voltages: 240VAC@5Amps, 120VAC@10/5Amps, 28VDC@10/5Amps.

Installation

Fibre ports must always be connected so that a left port is connected to a right port of the next node in the ring. Segments must obey the same rules; i.e. even if only two nodes are connected, the left port of one must connect to the right port of the next. All connections must be made with multimode or singlemode Fibre optic cable. Minimum use of patch panel connections is recommended, as each patch introduces optical loss.

Merging Legacy Fibre and Next Generation Fibre Networks

Connecting next generation 2L Transceiver/devices to Legacy device networks is possible, this is achieved via the copper twisted pair interface. Please contact us for further information.

Alternatively - Legacy Transceivers can be 'swapped out' of Legacy Routers, and replaced with 2L Next Generation transceivers/end plates. Thus creating a next generation fibre connection or network ring, whilst not disrupting the legacy twisted pair connections and maximizing the return on initial investment.

Ordering Information

Contact us: **email** sales@2ltec.com or support@2ltec.com
 Phone +44 (0) 1603 504 222

Part Number Format – 2L-A-BB-CDE(X)

Example Part Number - 2L-7-03-MS1X

- Intelligent LON[®] Fibre transceiver card with:
Two full-duplex Fibre ports with dual speed adaptable 1.25Mbs/2.50Mbs Neuron Ports.
- Left port 03km distance Fibre multimode Single Fibre WDM optics, tx1550/rx1310nm “SC”
- Right port 03km distance Fibre multimode Single Fibre WDM optics, tx1310/rx1550nm “SC”
- -40 to +80 operating temperature.

A = 7, Intelligent LON[®] Fibre transceiver card with:
Two full-duplex Fibre ports with dual speed adaptable 1.25Mbs/2.50Mbs Neuron Ports.

BB = 00, no selection.

BB = 03, 3km distance Fibre optics.

BB = 15, 15km distance Fibre optics.

BB = 25, 25km distance Fibre optics.

BB = 40, 40km distance Fibre optics.

BB = 60, 60km distance Fibre optics.

BB = 80, 80km distance Fibre optics.

C = 0, no selection.

C = S, singlemode Fibre

C = M, multimode Fibre

D = 0, no selection.

D = S, Fibre port connection “SC”.

E = 0, no selection.

E = 1, Fibre optic wavelength 1310/1550nm WDM single Fibre full duplex.

X= Extended Temperature range -40 to +80C

Note: Product will be supplied as standard operating temperature (0 to 70C) unless requested otherwise.

*Legacy router endplate adapting 2L Technologies Fibre Transceiver to ‘Legacy’ router box part number is ‘2L7-LEG’.

Legacy Fibre SMX transceiver optics note

Other manufacturers Fibre SMX transceivers are not compatible with 2L Technologies Next Generation Fibre optics SMX transceiver. Please contact us for further information.

WDM – Wave Division Multiplexing, two different Fibre optic wavelengths operating simultaneously providing full duplex operation over a single Fibre optic cable connection.

Current Fibre optic operating specifications

¹ Recommend using 50µm multimode Fibre cable for best multimode performance.

Multimode {1310/1550nm} WDM	Performance	Comment
Coupled optical power	Min. -10dbm Max. 0dBm	Optical power into 50/62.5µm MF.
Receive optical sensitivity	-28dBm	
¹ Optical Link budget	16dBm	
Maximum distance between nodes	3km	Assumes 2 Fibre connections and 2 splices.

² Recommend using 9µm singlemode Fibre cable for best singlemode performance.

Singlemode {1310/1550nm} WDM	Performance	Comment
Coupled optical power	Min. -14dbm Max. -8dBm	Optical power into 9µm SMF.
Receive optical sensitivity	-31dBm	
² Optical Link budget	17dBm	
Maximum distance between nodes	15km	Assumes 2 Fibre connections and 2 splices.

Singlemode {1310/1550nm} WDM	Performance	Comment
Coupled optical power	Min. -9dbm Max. -3dBm	Optical power into 9µm SMF.
Receive optical sensitivity	-31dBm	
² Optical Link budget	22dBm	
Maximum distance between nodes	25km	Assumes 2 Fibre connections and 2 splices.

Singlemode {1310/1550nm} WDM	Performance	Comment
Coupled optical power	Min. -8dbm Max. 0dBm	Optical power into 9µm SMF.
Receive optical sensitivity	-34dBm	
² Optical Link budget	26dBm	
Maximum distance between nodes	40km	Assumes 2 Fibre connections and 2 splices.

Singlemode {1310/1550nm} WDM	Performance	Comment
Coupled optical power	Min. -5dbm Max. -0dBm	Optical power into 9µm SMF.
Receive optical sensitivity	-34dBm	
² Optical Link budget	29dBm	
Maximum distance between nodes	60km	Assumes 2 Fibre connections and 2 splices.

Singlemode {1310/1550nm} WDM	Performance	Comment
Coupled optical power	Min. 0dbm Max. +5dBm	Optical power into 9µm SMF.
Receive optical sensitivity	-34dBm	
² Optical Link budget	33dBm	
Maximum distance between nodes	80km	Assumes 2 Fibre connections and 2 splices.

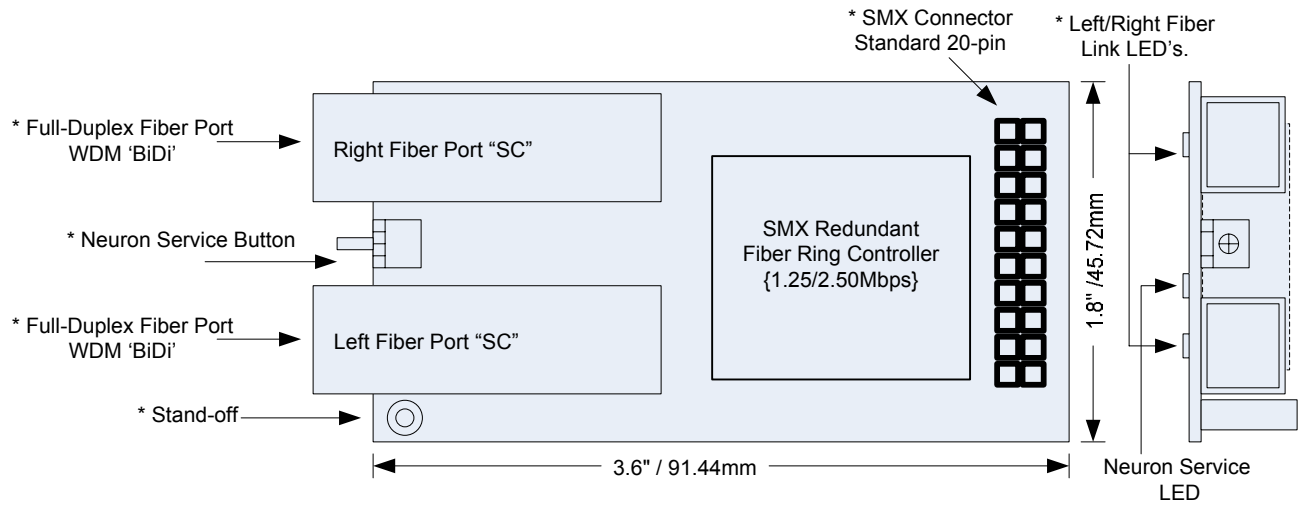

Next Generation, Intelligent LON - Fibre Optic Transceiver SMX card.

